

## 0.8A/40V Input, 800kHz Synchronous Step-Down Converter

### General Description

LN5017 is a current mode monolithic buck switching regulator. Operating with an input range of 4.5V~40V, the LN5017 delivers 800mA of continuous output current with two integrated N-Channel MOSFETs. The internal synchronous power switches provide high efficiency without the use of an external Schottky diode. At light loads, the regulator operates in continuous inductor current mode and low output ripple.

The LN5017 guarantees robustness with short-circuit protection, thermal protection, current run-away protection, and input under voltage lockout.

The LN5017 is available in 6-pin SOT23-6 package, which provides a compact solution with minimal external components.

### Features

- 4.5V to 40V Input Voltage Range
- 800mA output current
- High Efficiency: Up to 95%
- No Schottky Diode Required
- 0.8V Reference
- Slope Compensated Current Mode Control for Excellent Line and Load Transient Response
- Integrated internal compensation
- Stable with Low ESR Ceramic Output Capacitors
- Input under voltage lockout
- Short circuit protection
- Thermal Shutdown
- Inrush Current Limit and Soft Start
- -40°C to +125°C Temperature Range

东诚兴电子

www.dcx-ic.com

### Package

- SOT-23-6L

### Applications

- Distributed Power Systems
- Automotive Systems
- High Voltage Power Conversion
- Industrial Power Systems
- Battery Powered Systems

### Typical Application Circuit

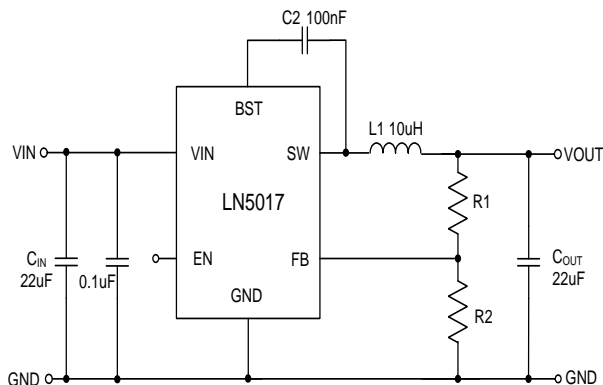

### Efficiency@VIN=12V 需要修改

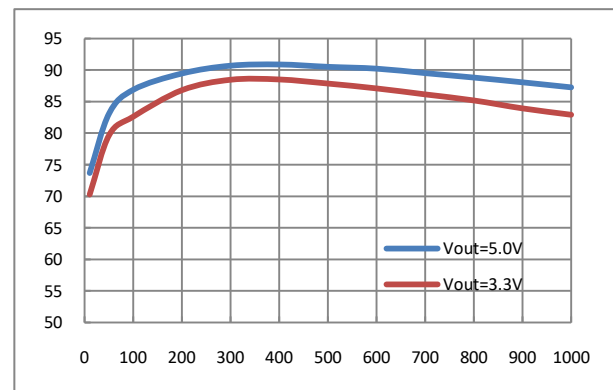

## ■ Ordering Information

### LN5017P①②③

Designator	Symbol	Description
①	H	External feedback, Feedback Voltage 0.8V
②	M	Package Type :SOT-23-6L
③	R	Embossed Tape : Standard Feed
	L	Embossed Tape : Reverse Feed

## ■ Pin Configuration

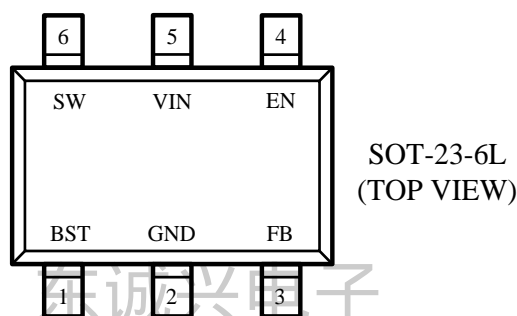

## ■ Pin Assignment

Pin Number	Pin Name	Function
SOT-23-6L		
1	BST	Bootstrap pin. Connect a 100nF capacitor from this pin to SW.
2	GND	Ground.
3	FB	Feedback Input. Connect an external resistor divider from the output to FB and GND to set VOUT.
4	EN	Enable pin for the IC. Drive this pin high to enable the part, low to disable.
5	VIN	Supply Voltage. Bypass with a 22 $\mu$ F ceramic capacitor to GND.
6	SW	Inductor Connection. Connect an inductor Between SW and the regulator output.

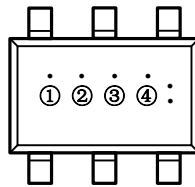
**■ Marking Rule**

 SOT-23-6L  
 (TOP VIEW)

① Represents the product name

Symbol	Product Name
7	LN5017P***

② Represents the feedback voltage

Symbol	Description
H	Feedback Voltage 0.8V

③ Represents the packaging information

Symbol	Package
M	SOT23-6L

④ Represents the assembly lot No.

0-9, A-Z; 0-9, A-Z mirror writing, repeated (G, I, J, O, Q, W exception)

**■ Absolute Maximum Ratings**

Parameter	Symbol	Maximum Rating		Unit
Input Voltage	$V_{IN}$	$V_{SS}-0.3 \sim V_{SS}+45$		V
SW Voltage		$V_{SS}-0.3 \sim V_{IN}+0.3$		
BST Voltage		$V_{SW}-0.3 \sim V_{SW} +6$		
FB Voltage		$V_{SS}-0.3 \sim V_{SS}+6$		
Power Dissipation	$P_D$	SOT-23-6L	600	mW
Thermal Resistance $\theta_{JC}$	$\theta_{JC}$	130		°C/W
Thermal Resistance $\theta_{JA}$	$\theta_{JA}$	170		°C/W
Operating Ambient Temperature	$T_{opr}$	-40~125		°C
Storage Temperature	$T_{stg}$	-40~+150		
ESD HBM (Human Body Mode)		2		KV

**Caution:** The absolute maximum ratings are rated values exceeding which the product could suffer physical damage. These values must therefore not be exceeded under any conditions.

■ Function Block Diagram

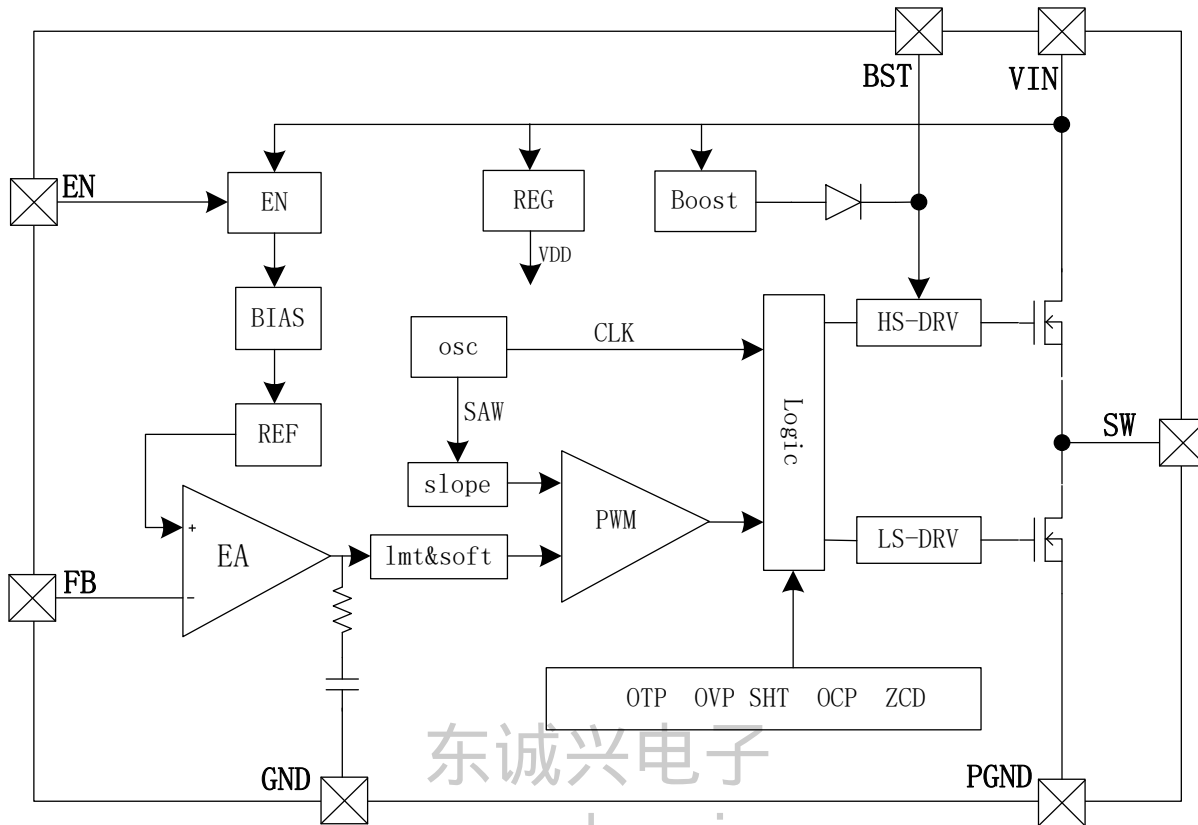

东诚兴电子  
www.dcx-ic.co

## ■ Electrical Characteristics

Note:  $V_{IN} = 12V$ ,  $V_{OUT} = 5.0V$ , unless otherwise specified. Typical values are at  $T_A = 25^\circ C$ )

Parameter	Symbol	Condition	Min	Typ	Max	Unit
Input Voltage	$V_{IN}$		4.5		40	V
VIN Under Voltage Protect	$V_{UV}$			4.3		V
VIN Under Voltage Protect Hys.	$V_{UV\_hys}$			0.2		V
<b>Supply Current</b>	<b><math>I_{Q1}</math></b>	$V_{EN}=2V$ , $V_{FB}=0.85V$		<b>3</b>		mA
Supply Shutdown Current	$I_{SD}$		-1		1	$\mu A$
FB Voltage	$V_{FB}$	$T_A=25^\circ C$ , $4.5V \leq V_{IN} \leq 40V$	0.776	0.8	0.824	V
Switching Frequency	$F_{OSC}$			800		kHz
Minimum On Time	$T_{ON\_MIN}$			200		ns
Maximum Duty Cycle	D <sub>MAX</sub>			90		%
High Side Switch On Resistance	$R_{DS(on)_H}$			450		m $\Omega$
Low Side Switch On Resistance	$R_{DS(on)_L}$			270		m $\Omega$
High Side Current Limit	$I_{LIM}$			2		A
EN Rising Threshold	$V_{ENH}$			1.3		V
EN Falling Threshold	$V_{ENL}$			1.2		V
EN Input Current	$I_{EN}$	$V_{EN}=5V$		2		$\mu A$
Thermal Shutdown	$T_{SHD}$			160		$^\circ C$
Thermal Shutdown Hys.	$T_{SHD\_Hys}$			20		$^\circ C$

## ■ Typical Performance Characteristics

$V_{in}=12V$ ,  $V_{out}=5.0V$ ,  $L=10\mu F$ ,  $C_{out}=10\mu F$ ,  $T_A=+25^\circ C$ , unless otherwise noted. (需要修改)

**Efficient @Vout=5.0V**

$C_{VIN}=22\mu F$ ,  $C_{OUT}=10\mu F$ ,  $C_{BST}=0.1\mu F$ ,  $L_{IND}=10\mu H$

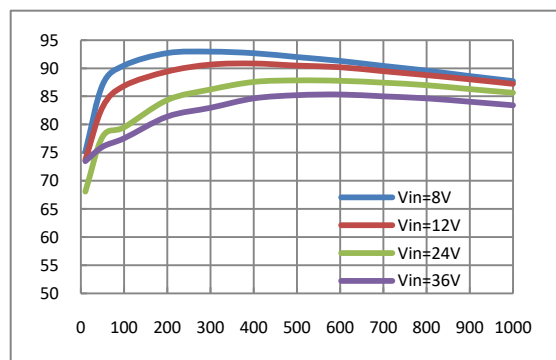

**Efficient @Vout=3.3V**

$C_{VIN}=22\mu F$ ,  $C_{OUT}=10\mu F$ ,  $C_{BST}=0.1\mu F$ ,  $L_{IND}=10\mu H$

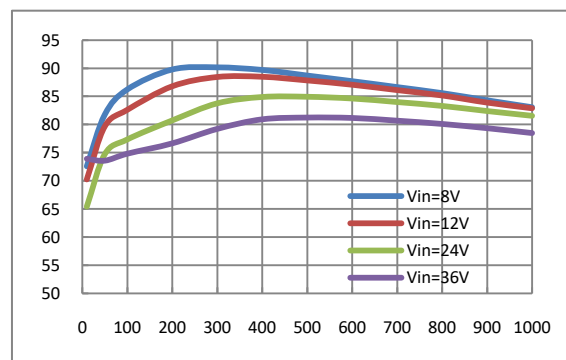

**Steady State Test**

Vin=12V, Vout=5.0V, Iout=800mA

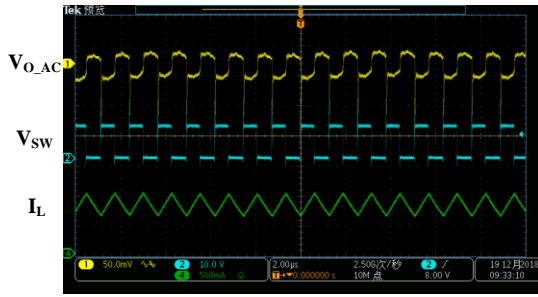

**Light Load Operation**

Vin=12V, Vout=5.0V, Iout=0A

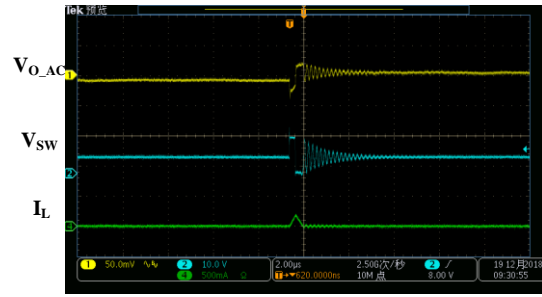

**Medium Load Operation**

Vin=12V, Vout=5.0V, Iout=400mA

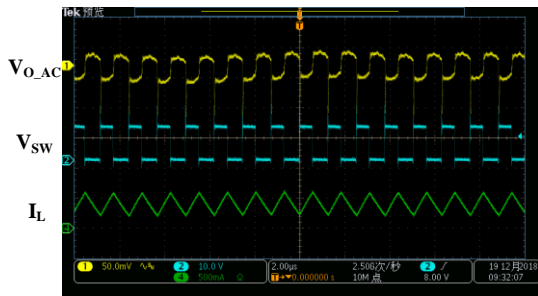

**Startup through Enable**

Vin=12V, Vout=5.0V, Iout=800mA (Resistive load)

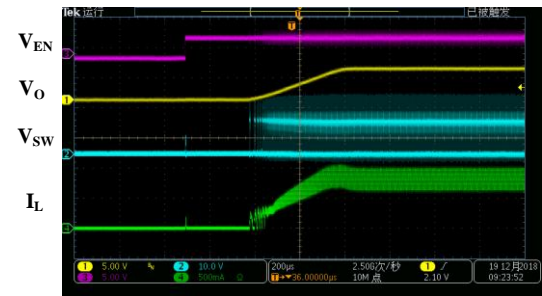

**Shutdown through Enable**

Vin=12V, Vout=5.0V, Iout=800mA (Resistive load)

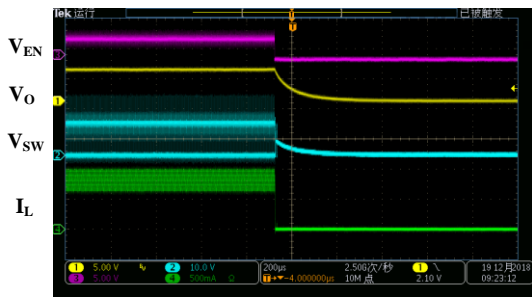

**Load Transient**

Load: 300mA ->800mA ->300mA

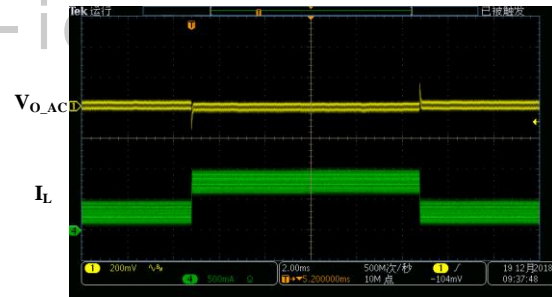

**Short Circuit Protection**

Vin=12V, Vout=5.0V, Iout=800mA - Short

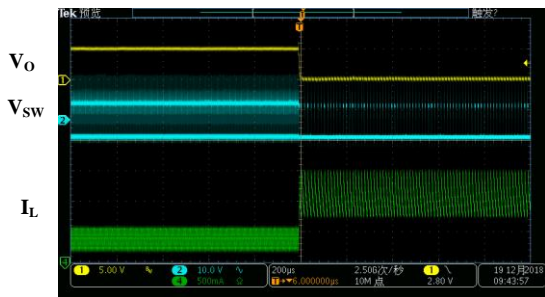

**Short Circuit Protection**

Vin=12V, Vout=5.0V, Iout= Short - 800mA

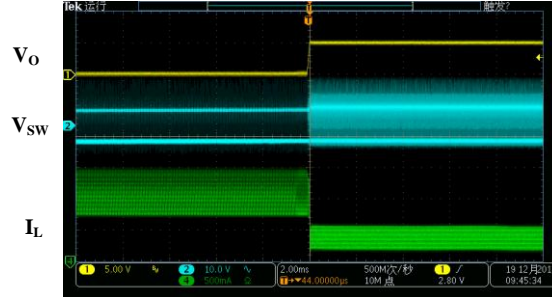

## ■ Functional Description

The LN5017 is a synchronous, current-mode, step-down regulator. It regulates input voltages from 4.5V to 40V, and is capable of supplying up to 800mA of load current.

### Current-Mode Control

The LN5017 utilizes current-mode control to regulate the output voltage. The output voltage is measured at the FB pin through a resistive voltage divider and the error is amplified by the internal transconductance error amplifier. Output of the internal error amplifier is compared with the switch current measured internally to control the output current.

### Continuous Current Mode

The LN5017 operates in continuous current mode at light load. In this mode, the LN5017 provides lower output voltage ripple.

### Shutdown Mode

The LN5017 shuts down when voltage at EN pin is below 0.3V. The entire regulator is off and the supply current consumed by the LN5017 drops below 0.1uA.

### Power Switch

N-Channel MOSFET switches are integrated on the LN5017 to down convert the input voltage to the regulated output voltage. Since the top MOSFET needs a gate voltage great than the input voltage, a boost capacitor connected between BST and SW pins is required to drive the gate of the top switch. The boost capacitor is charged by the internal 4.0V rail when SW is low.

### Vin Under Voltage Protection

A resistive divider can be connected between Vin and ground, with the central tap connected to EN, so that when Vin drops to the pre-set value, EN drops below 1.2V to trigger input under voltage lockout protection.

### Over-Current-Protection and Hiccup

At start-up, due to the high voltage at input and low voltage at output, current inertia of the output inductance can be easily built up, resulting in a large start-up output current. In the LN5017 used current limit of low side power mosfet to control the output current at start-up.

### Output Short Protection

When output is shorted to ground, output current rapidly reaches its peak current limit and the top power switch is turned off. And the bottom power switch is turned on and stay on until the output current falls below the current limit. When output current is below the current limit, the top power switch will be turned on again and if the output short is still present, the top power switch is turned off when the peak current limit is reached and the bottom power switch is turned on. This cycle goes on until the output short is removed and the regulator comes into normal operation again.

### Thermal Protection

When the temperature of the LN5017 rises above 160°C, it is forced into thermal shut-down. Only when core temperature drops below 140°C can the regulator becomes active again

## ■ Application Information

### Setting the Output Voltage

The external resistor divider is used to set the output voltage. Choose R1 and R2 follow the next table or calculated by following equation, where the internal reference voltage  $V_{REF}=0.8V$ .

$$\frac{R1}{R2} = \frac{V_{OUT} - V_{REF}}{V_{REF}}$$

$V_{OUT}(V)$	R2(k $\Omega$ )	R1(k $\Omega$ )
2.5	24	51
3.3	24	75
5.0	24	126

### Inductor Selection

A 4.7 $\mu H$  to 22 $\mu H$  inductor with a DC current rating of at least 25% percent higher than the maximum load current is recommended for most applications. For highest efficiency, the inductor DC resistance should be less than 15m $\Omega$ . For most designs, the inductance value can be derived from the following equation.

$$L > \frac{V_{OUT} \times (V_{IN} - V_{OUT})}{V_{IN} \times \Delta I_L \times f_{OSC}} \quad \text{Where } \Delta I_L \text{ is the inductor ripple current.}$$

Choose  $\Delta I_L$  to be approximately 30% of the maximum load current.

Under light load conditions below 100mA, larger inductance is recommended for improved efficiency.

Note: If the output voltage is less than 2.5V, it is recommended to use a larger inductance and add a small capacitance (10nF) parallel to R1.

### Input Capacitor Selection

The input capacitor reduces the surge current drawn from the input and switching noise from the device. The input capacitor impedance at the switching frequency should be less than input source impedance to prevent high frequency switching current passing to the input. A low ESR input capacitor sized for maximum RMS current must be used. Ceramic capacitors with X5R or X7R dielectrics are highly recommended because of their low ESR and small temperature coefficients. A 22 $\mu F$  ceramic capacitor for most applications is sufficient. Include a capacitor with a value of 0.1  $\mu F$  for high-frequency filtering and place it as close as possible to the device pins.

### Output Capacitor Selection

The output capacitor ( $C_{OUT}$ ) is required to maintain the DC output voltage, and the capacitance value determines the output ripple voltage. The output voltage ripple can be calculated by:

$$\Delta V_{OUT} = \frac{V_{OUT} \times (V_{IN} - V_{OUT})}{V_{IN} \times f_{OSC} \times L} \times \left( R_{ESR} + \frac{1}{8 \times f_{OSC} \times C_{OUT}} \right)$$

Where L is the inductor value and  $R_{ESR}$  is the equivalent series resistance (ESR) value of the output capacitor.

The output capacitor can be low ESR electrolytic, tantalum or ceramic, which lower ESR capacitors get lower output ripple voltage.

The characteristics of the output capacitor also affect the stability of the regulation system, and a 10 $\mu F$  ceramic capacitor is recommended in typical application. The LN5017 can be optimized for a wide range of capacitance and ESR values.



## ■ Application Information

For minimum noise problem and best operating performance, the PCB is preferred to following the guidelines as reference.

1. Place the input decoupling capacitor as close to LN5017 (VIN pin and GND) as possible to eliminate noise at the input pin.  
The loop area formed by input capacitor and GND must be minimized.
2. Put the feedback trace as far away from the inductor and noisy power traces as possible.
3. The ground plane on the PCB should be as large as possible for better heat dissipation.
4. If little output ripple voltage needed, please use larger inductor.
5. If uses higher power voltage, please use larger inductor.

## ■ Reference Design

### Reference 1:

$V_{IN}$  : 5.0V~40V

$V_{OUT}$  : 3.3V

$I_{OUT}$  : 0~800mA

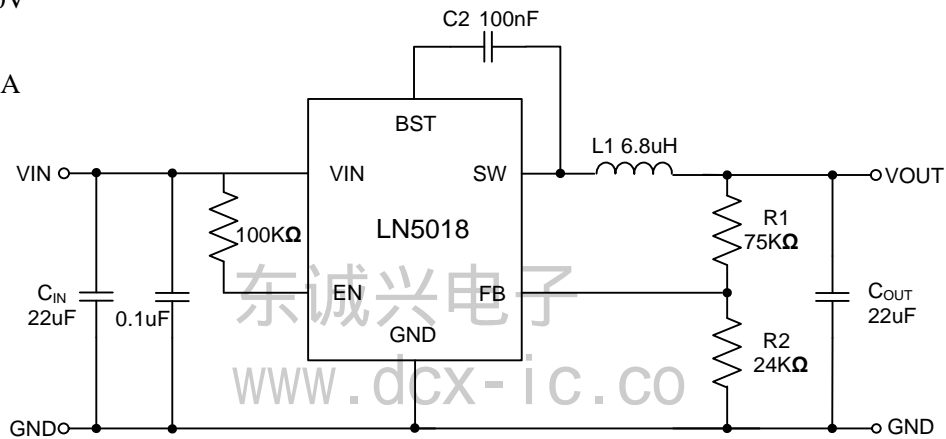

### Reference 2:

$V_{IN}$  : 6.5V~40V

$V_{OUT}$  : 5.0V

$I_{OUT}$  : 0~800mA

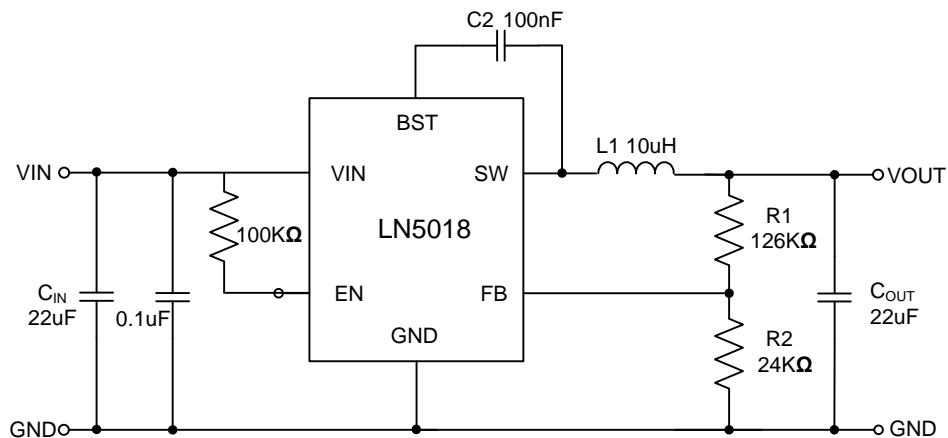

**Package Information**

- SOT-23-6L

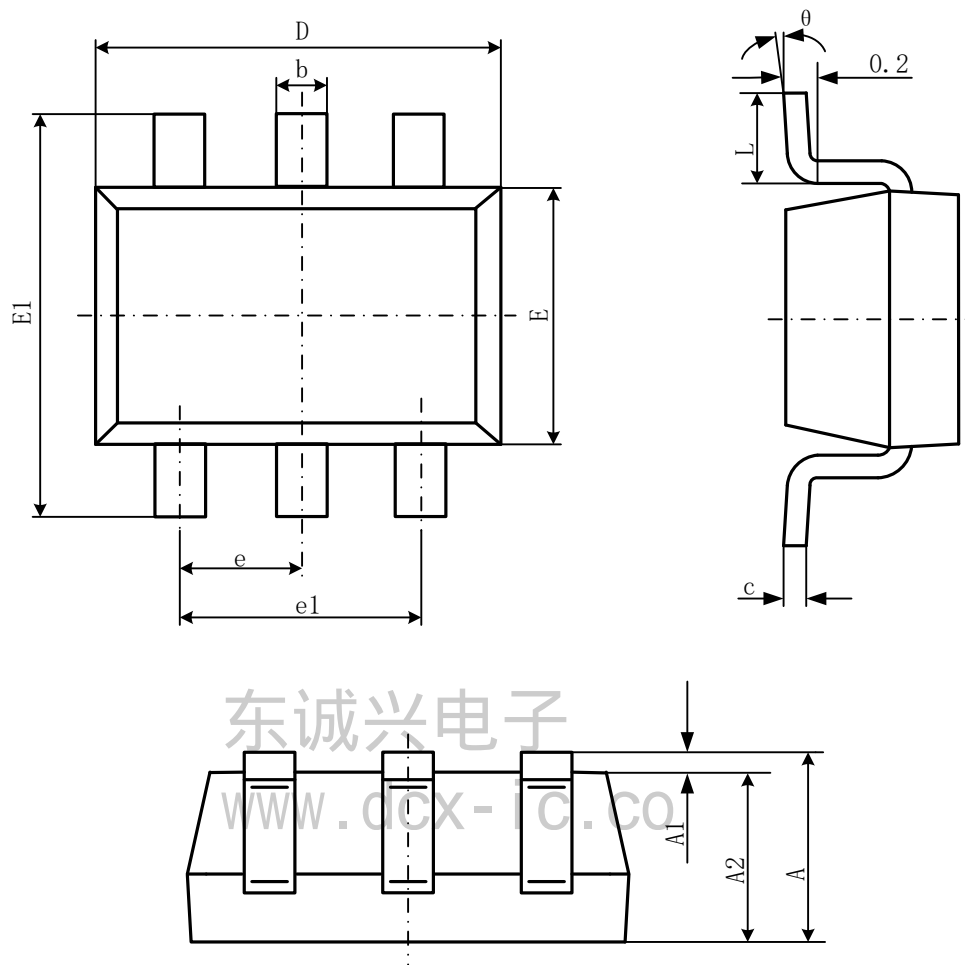

Symbol	Dimensions In Millimeters		Dimensions In Inches	
	Min	Max	Min	Max
A	1.050	1.250	0.041	0.049
A1	0.000	0.100	0.000	0.004
A2	1.050	1.150	0.041	0.045
b	0.300	0.500	0.012	0.020
c	0.100	0.200	0.004	0.008
D	2.820	3.020	0.111	0.119
E	1.500	1.700	0.059	0.067
E1	2.650	2.950	0.104	0.116
e	0.950(BSC)		0.037(BSC)	
e1	1.800	2.000	0.071	0.079
L	0.300	0.600	0.012	0.024
$\theta$	0°	8°	0°	8°