

## P-Channel Enhancement Mode MOSFET

### Description

The NP3415E uses advanced trench technology to provide excellent  $R_{DS(ON)}$ , low gate charge and operation with gate voltages as low as 1.8V. This device is suitable for use as a load switch or in PWM applications.

### General Features

- ◆  $V_{DS} = -20V$ ,  $I_D = -4A$   
 $R_{DS(ON)}(Typ.) = 42m\Omega$  @  $V_{GS} = -2.5V$   
 $R_{DS(ON)}(Typ.) = 31.5m\Omega$  @  $V_{GS} = -4.5V$
- ◆ High power and current handling capability
- ◆ Lead free product is acquired
- ◆ Surface mount package
- ◆ ESD Rating: 2500V HBM

### Application

- ◆ PWM applications
- ◆ Load switch

### Package

- ◆ SOT-23-3L

### Schematic diagram

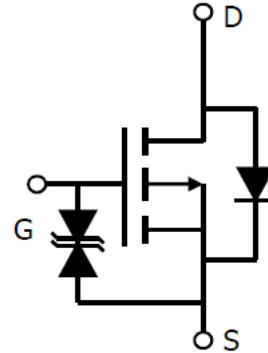

### Marking and pin assignment

SOT-23-3L  
(TOP VIEW)

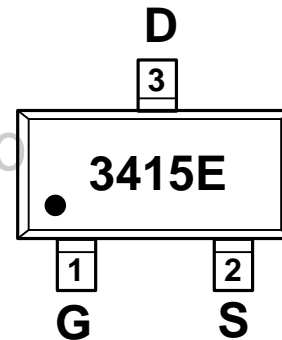

### Ordering Information

Part Number	Storage Temperature	Package	Devices Per Reel
NP3415EMR	-55°C to +150°C	SOT-23-3L	3000

### Absolute Maximum Ratings (TA=25°C unless otherwise noted)

parameter	symbol	limit	unit
Drain-source voltage	$V_{DS}$	-20	V
Gate-source voltage	$V_{GS}$	±8	V
Drain current-continuous <sup>a</sup> @Tj=125°C -pulse <sup>b</sup>	$I_D$	-4	A
	$I_{DM}$	-30	A
Maximum power dissipation	$P_D$	$T_A=25^\circ C$	1
		$T_A=70^\circ C$	1.4
Operating junction Temperature range	$T_j$	-55—150	°C

**Electrical Characteristics** (TA=25°C unless otherwise noted)

Parameter	Symbol	Condition	Min	Typ	Max	Unit
<b>OFF Characteristics</b>						
Drain-source breakdown voltage	$BV_{DSS}$	$V_{GS}=0V, I_D=-250\mu A$	-20	-	-	V
Zero gate voltage drain current	$I_{DSS}$	$V_{DS}=-20V, V_{GS}=0V$	-	-	-1	$\mu A$
Gate-body leakage	$I_{GSS}$	$V_{DS}=0V, V_{GS}=\pm 8V$	-	-	$\pm 10$	$\mu A$
<b>ON Characteristics</b>						
Gate threshold voltage	$V_{GS(th)}$	$V_{DS}=V_{GS}, I_D=-250\mu A$	-0.4	-0.59	-0.9	V
Drain-source on-state resistance	$R_{DS(ON)}$	$V_{GS}=-4.5V, I_D=-4A$	-	31.5	45	m $\Omega$
		$V_{GS}=-2.5V, I_D=-4A$	-	38.5	60	
Forward transconductance	$g_{fs}$	$V_{GS}=-5V, I_D=-4A$	8	-	-	S
<b>Dynamic Characteristics</b>						
Input capacitance	$C_{ISS}$	$V_{DS}=-10V, V_{GS}=0V$ $f=1.0MHz$	-	751	-	pF
Output capacitance	$C_{OSS}$		-	115	-	
Reverse transfer capacitance	$C_{RSS}$		-	80	-	
<b>Switching Characteristics</b>						
Turn-on delay time	$t_{D(ON)}$	$V_{DD}=-10V$ $I_D=-2.8A$ $V_{GEN}=-4.5V$ $R_L=10ohm$ $R_{GEN}=-60ohm$	-	13	-	ns
Rise time	$t_r$		-	9	-	
Turn-off delay time	$t_{D(OFF)}$		-	19	-	
Fall time	$t_f$		-	29	-	
Total gate charge	$Q_g$	$V_{DS}=-10V, I_D=-3A$ $V_{GS}=-4.5V$	-	9.3	-	nC
Gate-source charge	$Q_{gs}$		-	1	-	
Gate-drain charge	$Q_{gd}$		-	2.2	-	
<b>DRAIN-SOURCE DIODE CHARACTERISTICS</b>						
Diode forward voltage	$V_{SD}$	$V_{GS}=0V, I_S=-1.25A$	-	-0.81	-1.2	V

**Notes:**

- surface mounted on FR4 board,  $t \leq 10sec$
- pulse test: pulse width  $\leq 300\mu s$ , duty  $\leq 2\%$
- guaranteed by design, not subject to production testing

**Thermal Characteristics**

Thermal Resistance junction-to ambient	Rth JA	100	$^{\circ}C/W$
--	--------	-----	---------------

## Typical Performance Characteristics

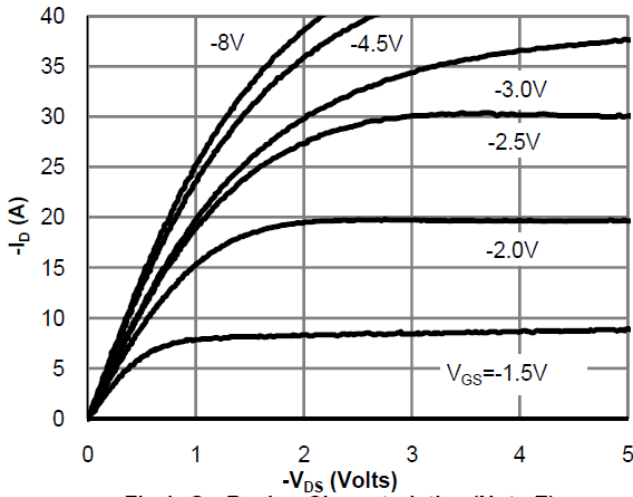

Fig 1: On-Region Characteristics (Note E)

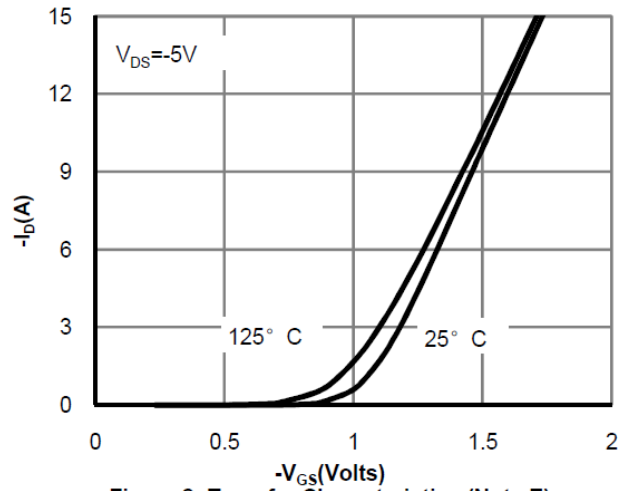

Figure 2: Transfer Characteristics (Note E)

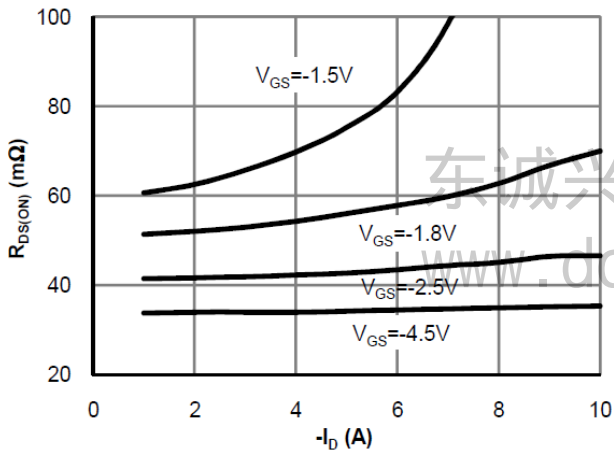

Figure 3: On-Resistance vs. Drain Current and Gate Voltage (Note E)

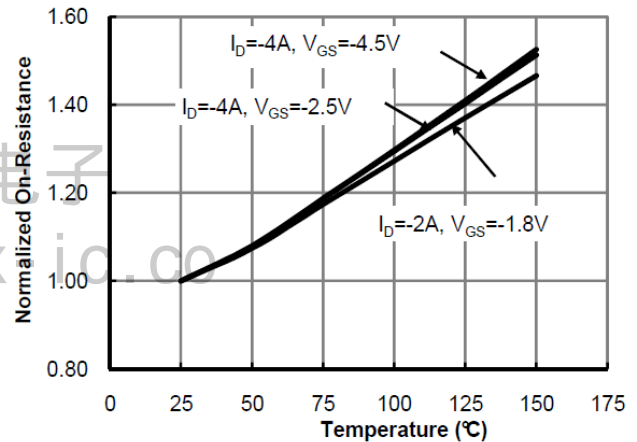

Figure 4: On-Resistance vs. Junction Temperature (Note E)

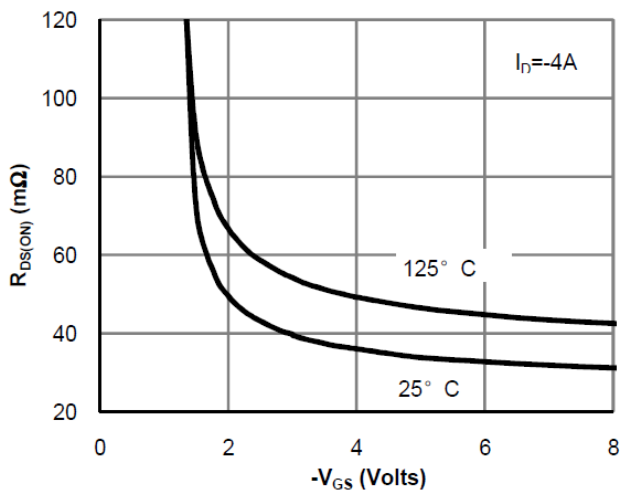

Figure 5: On-Resistance vs. Gate-Source Voltage (Note E)

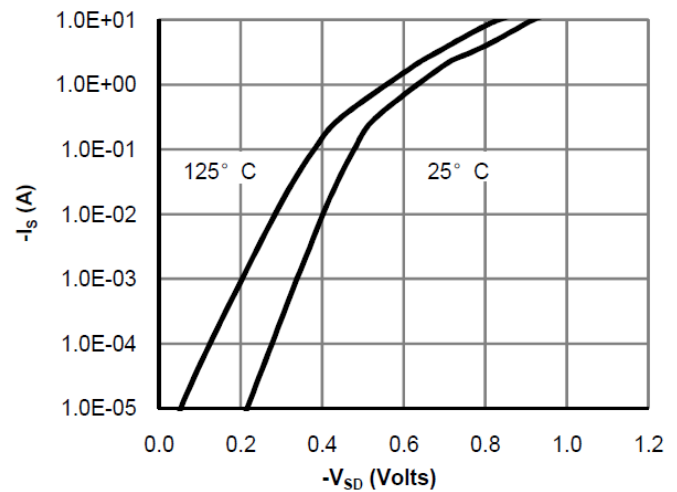

Figure 6: Body-Diode Characteristics (Note E)

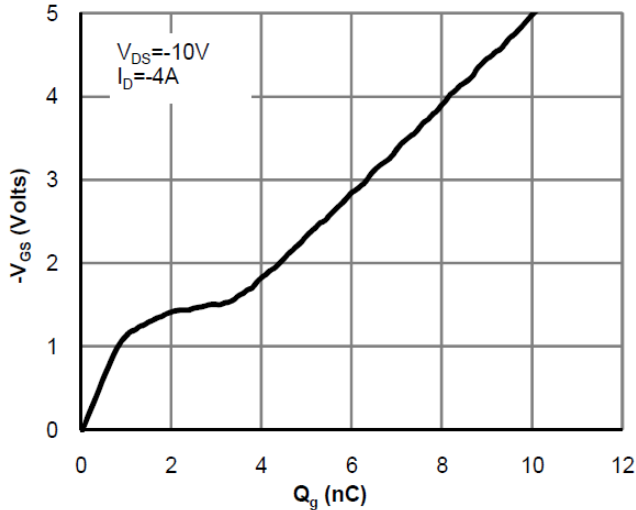

Figure 7: Gate-Charge Characteristics

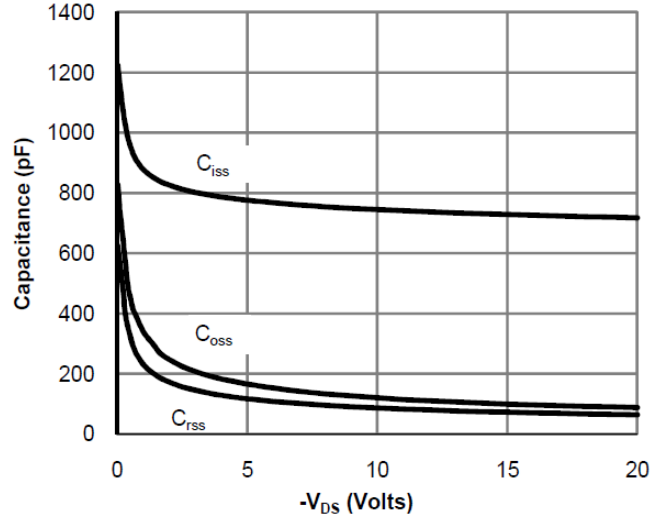

Figure 8: Capacitance Characteristics

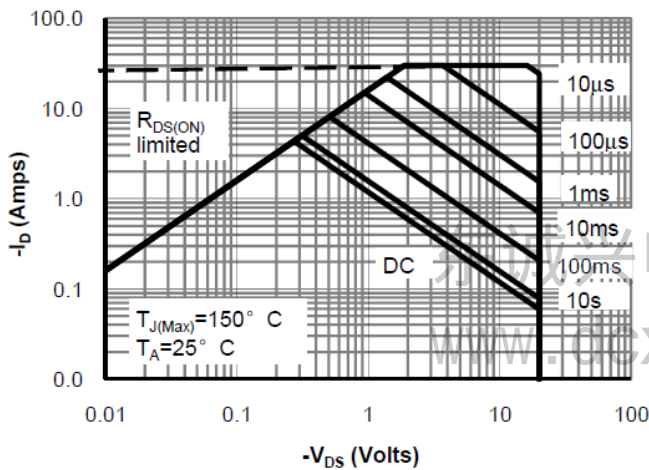

Figure 9: Maximum Forward Biased Safe Operating Area (Note F)

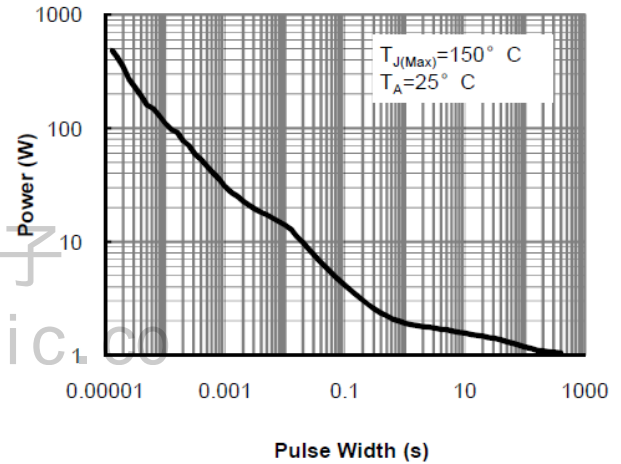

Figure 10: Single Pulse Power Rating Junction-to-Ambient (Note F)

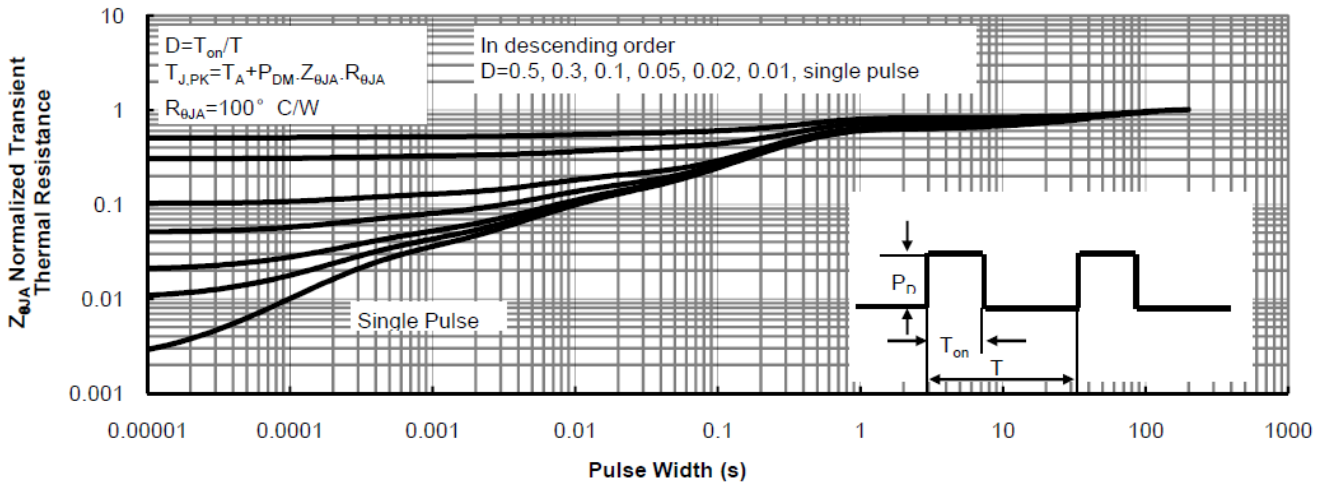
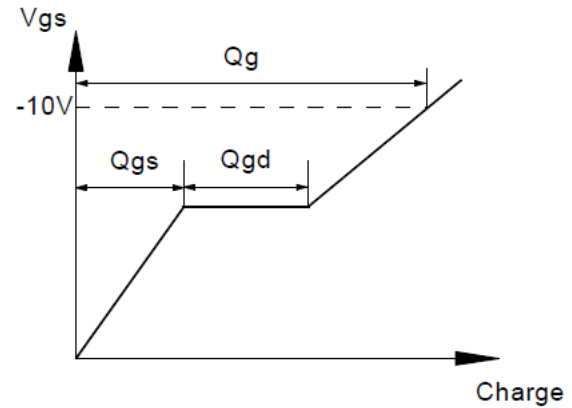
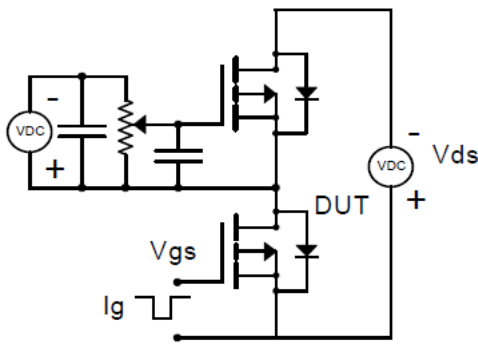
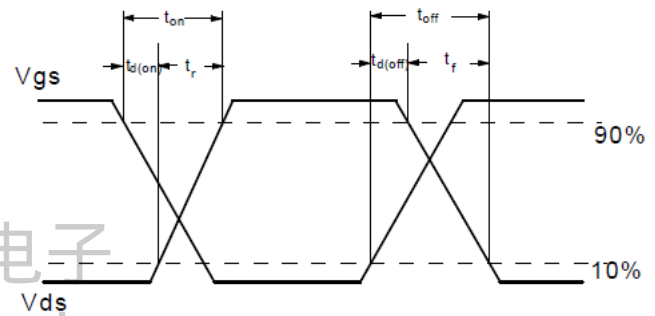
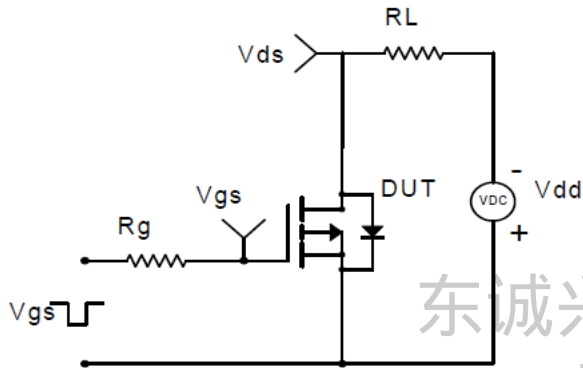

Figure 11: Normalized Maximum Transient Thermal Impedance (Note F)

Gate Charge Test Circuit & Waveform



Resistive Switching Test Circuit & Waveforms



Diode Recovery Test Circuit & Waveforms

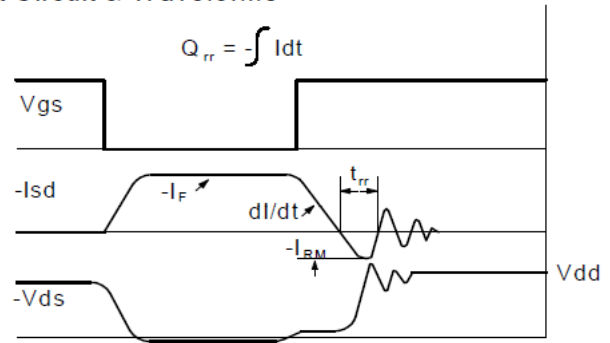
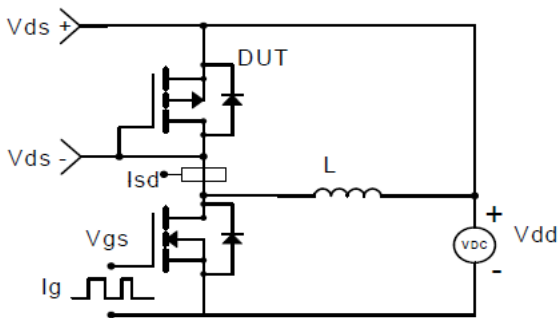

## Package Information

- SOT-23-3L

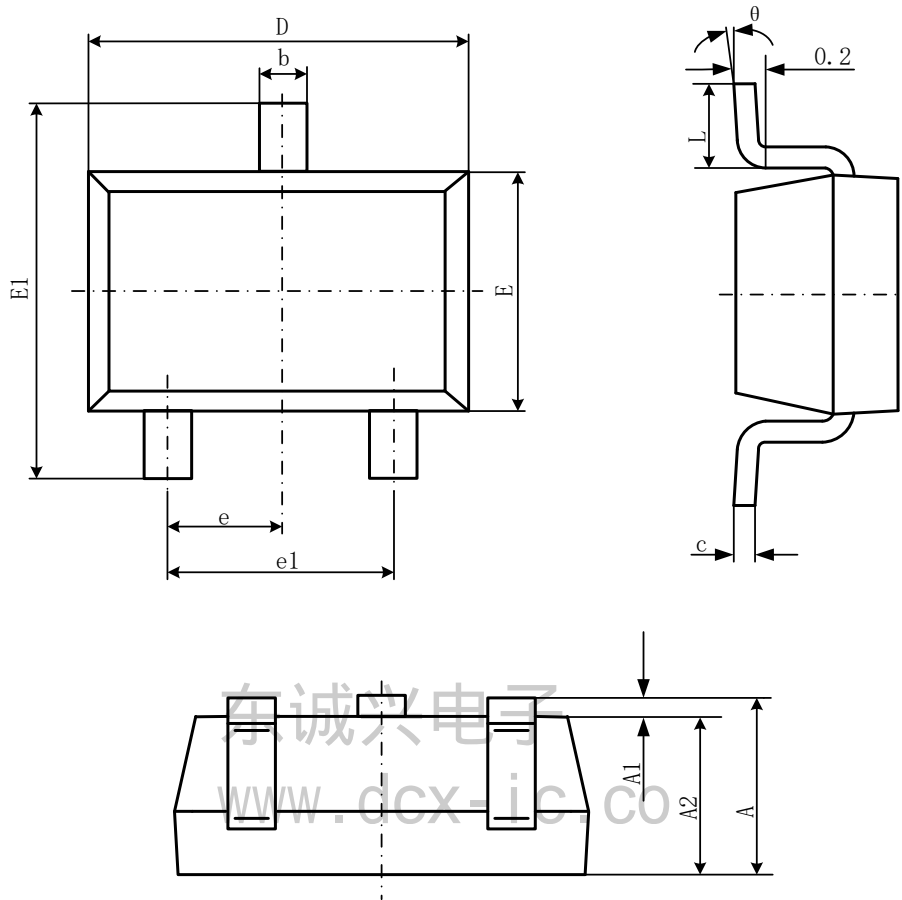

Symbol	Dimensions In Millimeters		Dimensions In Inches	
	Min	Max	Min	Max
A	1.050	1.250	0.041	0.049
A1	0.000	0.100	0.000	0.004
A2	1.050	1.150	0.041	0.045
b	0.300	0.500	0.012	0.020
c	0.100	0.200	0.004	0.008
D	2.820	3.020	0.111	0.119
E	1.500	1.700	0.059	0.067
E1	2.650	2.950	0.104	0.116
e	0.950(BSC)		0.037(BSC)	
e1	1.800	2.000	0.071	0.079
L	0.300	0.600	0.012	0.024
$\theta$	0°	8°	0°	8°