

500mA, Low Quiescent, Low Dropout LDO Linear Regulators

General Description

ME6210 series are low quiescent, low-dropout linear voltage regulators. ME6210 series are based on the CMOS process and allow high voltage input. They allow operation voltage as high as 18V.

ME6210 series have short circuit protection function.

Features

- High output accuracy: $\pm 2\%$
- Input voltage: 1.8V ~ 18V
- Output voltage: 1.5V ~ 5.0V
- Ultra-low quiescent current (Typ. = 1.5 μ A)
- Output Current: $I_{out} = 500\text{mA}$
(When $V_{in} = 4\text{V}$ and $V_{out} = 3\text{V}$)
- Low dropout voltage: 11mV @ $I_{out} = 10\text{mA}$ (Typ. $V_{out} = 3.0\text{V}$)
- Input good stability: Typ. 0.03% / V
- Short-circuit Current: Typ. 50mA
- Ceramic capacitor can be used

Typical Application

- Power source for home electric/electronic appliances
- Power source for battery-powered devices
- Power source for personal communication devices

Package

- 3-pin SOT23-3、SPT89-3

Typical Application Circuit

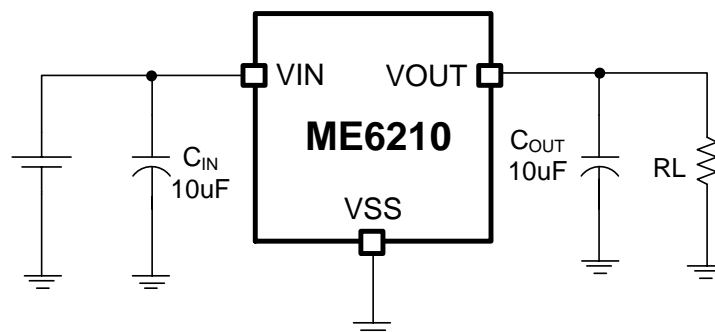

Selection Guide

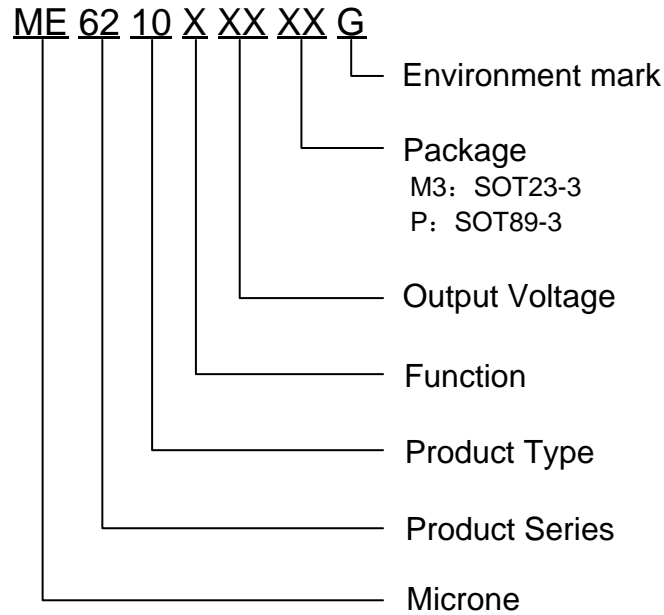

product series	product description
ME6210A15PG	$V_{OUT} = 1.5V$; Package: SOT89-3
ME6210A25M3G	$V_{OUT} = 2.5V$; Package: SOT23-3
ME6210A28M3G	$V_{OUT} = 2.8V$; Package: SOT23-3
ME6210A28PG	$V_{OUT} = 2.8V$; Package: SOT89-3
ME6210A30M3G	$V_{OUT} = 3.0V$; Package: SOT23-3
ME6210A30PG	$V_{OUT} = 3.0V$; Package: SOT89-3
ME6210A33M3G	$V_{OUT} = 3.3V$; Package: SOT23-3
ME6210A33PG	$V_{OUT} = 3.3V$; Package: SOT89-3
ME6210A36PG	$V_{OUT} = 3.6V$; Package: SOT89-3
ME6210A40PG	$V_{OUT} = 4.0V$; Package: SOT89-3
ME6210A50M3G	$V_{OUT} = 5.0V$; Package: SOT23-3
ME6210A50PG	$V_{OUT} = 5.0V$; Package: SOT89-3

- NOTE:**
1. At present ,there are eight kinds of voltage value: 1.5、2.5、2.8V、3.0V、3.3V、3.6V、4.0V、5.0V。
 2. If you need other voltage and package, please contact our sales staff.

Pin Configuration

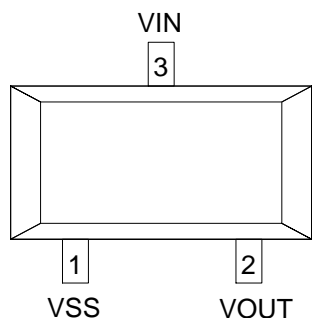

SOT23-3

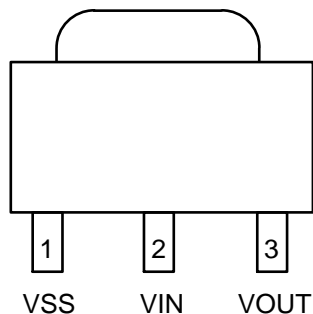

SOT89-3

Pin Assignment

Pin Number		Name	Function
M3	P		
SOT23-3	SOT89-3		
1	1	VSS	Ground
2	3	VOUT	Output
3	2	VIN	Input

Absolute Maximum Ratings

Parameter	Symbol	Description	Units
Input Voltage	V_{IN}	18	V
Output Current	I_{OUT}	700	mA
Output Voltage	V_{OUT}	$V_{SS}-0.3 \sim V_{OUT}+0.3$	V
Power Dissipation	SOT23-3	P_d	0.54
	SOT89-3	P_d	1.25
Thermal resistance (Junction to air)	SOT23-3	θ_{JA}	230
	SOT89-3	θ_{JA}	100
Maximum junction temperature	T_J	-40 ~ +150	°C
Operating Ambient Temperature	T_{Opr}	-40 ~ +85	°C
Storage Temperature	T_{stg}	-55 ~ +150	°C
Lead Temperature		260°C, 10sec	

Block Diagram

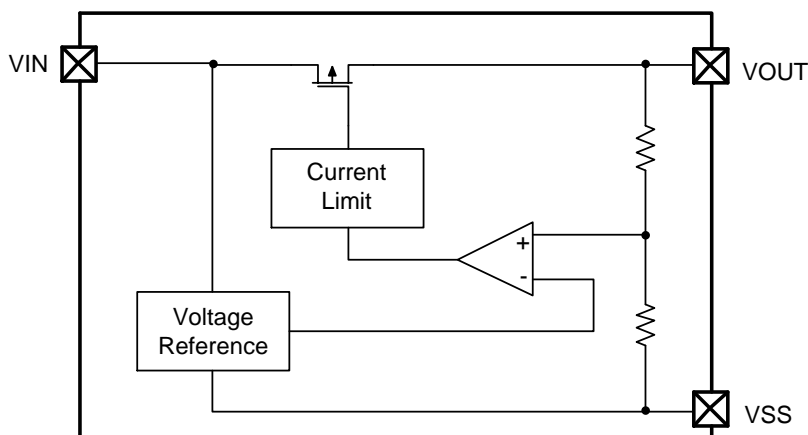

Electrical Characteristics

ME6210A15 ($V_{IN} = V_{OUT} + 1.5V$, $C_{IN} = C_{OUT} = 10\mu F$, $T_a = 25^\circ C$, unless otherwise noted)

Parameter	Symbol	Conditions	Min.	Typ.	Max.	Units
Output Voltage	$V_{OUT(E)}$ (Note 2)	$I_{OUT} = 40mA$, $V_{IN} = V_{OUT} + 1.5V$	X 0.98	$V_{OUT(T)}$ (Note 1)	X 1.02	V
Input Voltage	V_{IN}		-	-	18	V
Maximum Output Current	I_{OUT_max}	$V_{IN} = V_{OUT} + 1.5V$	-	500	-	mA
Load Regulation	ΔV_{OUT}	$V_{IN} = V_{OUT} + 1.5V, 1mA \leq I_{OUT} \leq 200mA$	-	12	30	mV
Dropout Voltage(Note 3)	V_{DIF1}	$I_{OUT} = 10mA$	-	40	60	mV
	V_{DIF2}	$I_{OUT} = 100mA$	-	330	500	mV
	V_{DIF3}	$I_{OUT} = 200mA$	-	560	840	mV
Supply Current	I_{SS}	$V_{IN} = V_{OUT} + 1.5V$	-	1.5	2.5	μA
Line Regulations	$\frac{\Delta V_{OUT}}{\Delta V_{IN} \times V_{OUT}}$	$I_{OUT} = 10mA$ $V_{OUT} + 1.5V \leq V_{IN} \leq 18V$	-	0.03	0.1	%/V
Temperature coefficient	$\frac{\Delta V_{OUT}}{\Delta T_a \times V_{OUT}}$	$V_{IN} = V_{OUT} + 1.5V, I_{OUT} = 10mA$ $-40^\circ C \leq T_a \leq 125^\circ C$	-	± 60	± 100	Ppm/ $^\circ C$
Short-circuit Current	I_{short}	$V_{IN} = V_{OUT} + 1.5V$	-	70	100	mA

ME6210A30 ($V_{IN} = V_{OUT} + 1.0V$, $C_{IN} = C_{OUT} = 10\mu F$, $T_a = 25^\circ C$, unless otherwise noted)

Parameter	Symbol	Conditions	Min.	Typ.	Max.	Units
Output Voltage	$V_{OUT(E)}$ (Note 2)	$I_{OUT} = 40mA$, $V_{IN} = V_{OUT} + 1V$	X 0.98	$V_{OUT(T)}$ (Note 1)	X 1.02	V
Input Voltage	V_{IN}		-	-	18	V
Maximum Output Current	I_{OUT_max}	$V_{IN} = V_{OUT} + 1V$	-	500	-	mA
Load Regulation	ΔV_{OUT}	$V_{IN} = V_{OUT} + 1V, 1mA \leq I_{OUT} \leq 200mA$	-	12	30	mV
Dropout Voltage(Note 3)	V_{DIF1}	$I_{OUT} = 10mA$	-	11	14	mV
	V_{DIF2}	$I_{OUT} = 100mA$	-	110	140	mV

	V_{DIF3}	$I_{OUT} = 200mA$	-	220	280	mV
Supply Current	I_{SS}	$V_{IN} = V_{OUT} + 1V$	-	1.5	2.5	μA
Line Regulations	$\frac{\Delta V_{OUT}}{\Delta V_{IN} \times V_{OUT}}$	$I_{OUT} = 10mA$ $V_{OUT} + 1V \leq V_{IN} \leq 18V$	-	0.03	0.1	%/V
Temperature coefficient	$\frac{\Delta V_{OUT}}{\Delta T_a \times V_{OUT}}$	$V_{IN} = V_{OUT} + 1V, I_{OUT} = 10mA$ $-40^{\circ}C \leq T_a \leq 125^{\circ}C$	-	± 60	± 100	Ppm/ $^{\circ}C$
Short-circuit Current	I_{short}	$V_{IN} = V_{OUT} + 1V$	-	50	70	mA

ME6210A33 ($V_{IN} = V_{OUT} + 1.0V$, $C_{IN} = C_{OUT} = 10\mu F$, $T_a = 25^{\circ}C$, unless otherwise noted)

Parameter	Symbol	Conditions	Min.	Typ.	Max.	Units
Output Voltage	$V_{OUT(E)}$ (Note 2)	$I_{OUT} = 40mA$, $V_{IN} = V_{OUT} + 1V$	X 0.98	$V_{OUT(T)}$ (Note 1)	X 1.02	V
Input Voltage	V_{IN}		-	-	18	V
Maximum Output Current	I_{OUT_max}	$V_{IN} = V_{OUT} + 1V$	-	500	-	mA
Load Regulation	ΔV_{OUT}	$V_{IN} = V_{OUT} + 1V, 1mA \leq I_{OUT} \leq 200mA$	-	12	30	mV
Dropout Voltage(Note 3)	V_{DIF1}	$I_{OUT} = 10mA$	-	10	13	mV
	V_{DIF2}	$I_{OUT} = 100mA$	-	100	130	mV
	V_{DIF3}	$I_{OUT} = 200mA$	-	200	260	mV
Supply Current	I_{SS}	$V_{IN} = V_{OUT} + 1V$	-	1.6	2.5	μA
Line Regulations	$\frac{\Delta V_{OUT}}{\Delta V_{IN} \times V_{OUT}}$	$I_{OUT} = 10mA$ $V_{OUT} + 1V \leq V_{IN} \leq 18V$	-	0.03	0.1	%/V
Temperature coefficient	$\frac{\Delta V_{OUT}}{\Delta T_a \times V_{OUT}}$	$V_{IN} = V_{OUT} + 1V, I_{OUT} = 10mA$ $-40^{\circ}C \leq T_a \leq 125^{\circ}C$	-	± 60	± 100	Ppm/ $^{\circ}C$
Short-circuit Current	I_{short}	$V_{IN} = V_{OUT} + 1V$	-	50	70	mA

ME6210A50 ($V_{IN} = V_{OUT} + 1.0V$, $C_{IN} = C_{OUT} = 10\mu F$, $T_a = 25^{\circ}C$, unless otherwise noted)

Parameter	Symbol	Conditions	Min.	Typ.	Max.	Units
Output Voltage	$V_{OUT(E)}$ (Note 2)	$I_{OUT} = 40mA$, $V_{IN} = V_{OUT} + 1V$	X 0.98	$V_{OUT(T)}$ (Note 1)	X 1.02	V
Input Voltage	V_{IN}		-	-	18	V
Maximum Output Current	I_{OUT_max}	$V_{IN} = V_{OUT} + 1V$	-	500	-	mA
Load Regulation	ΔV_{OUT}	$V_{IN} = V_{OUT} + 1V, 1mA \leq I_{OUT} \leq 200mA$	-	10	30	mV
Dropout Voltage(Note 3)	V_{DIF1}	$I_{OUT} = 10mA$	-	8	11	mV
	V_{DIF2}	$I_{OUT} = 100mA$	-	80	110	mV
	V_{DIF3}	$I_{OUT} = 200mA$	-	160	220	mV
Supply Current	I_{SS}	$V_{IN} = V_{OUT} + 1V$	-	1.7	2.5	μA
Line Regulations	$\frac{\Delta V_{OUT}}{\Delta V_{IN} \times V_{OUT}}$	$I_{OUT} = 10mA$ $V_{OUT} + 1V \leq V_{IN} \leq 18V$	-	0.03	0.1	%/V
Temperature coefficient	$\frac{\Delta V_{OUT}}{\Delta T_a \times V_{OUT}}$	$V_{IN} = V_{OUT} + 1V, I_{OUT} = 10mA$ $-40^{\circ}C \leq T_a \leq 125^{\circ}C$	-	± 60	± 100	Ppm/ $^{\circ}C$
Short-circuit Current	I_{short}	$V_{IN} = V_{OUT} + 1V$	-	50	70	mA

- Note:**
1. $V_{OUT}(T)$: Specified Output Voltage
 2. $V_{OUT}(E)$: Effective Output Voltage (ie. The output voltage when “ $V_{OUT}(T)+1.0V$ ”is provided at the V_{in} pin while maintaining a certain lout value.)
 3. $V_{DIF}: V_{IN1} - V_{OUT}(E)'$
 V_{IN1} : The input voltage when $V_{OUT}(E)'$ appears as input voltage is gradually decreased.
 $V_{OUT}(E)'$ =A voltage equal to 98% of the output voltage whenever an amply stabilized lout and $\{V_{OUT}(T) +1.0V\}$ is input.

Precautions

- During the test, if AC/DC power supply and the ceramic chip capacitors collocation is used, there may be serious voltage spike phenomenon instantaneously. When the power supply access to 15V, the voltage is rushed to about 30V instantaneously. Because of exceeding the limit voltage of chip, the chip is damaged. If you string a small resistance of 1 ohm in the input end during the test, the peak phenomenon can be avoided.
- In the test, there is serious burr phenomenon only when the AC/DC power is used with ceramic chip capacitors. But electrolytic capacitors and tantalum capacitance won't appear above phenomenon. Please be sure to pay attention to this point when you use AC/DC power.
- In normal use, when any type of capacitor is used with battery or the supply of fire power, the above phenomenon doesn't occur.

东诚兴电子
www.dcx-ic.co

Type Characteristics

(1) Output Voltage VS. Output Current

($T_a = 25\text{ }^\circ\text{C}$, $V_{IN}=4\text{V}$) ME6210A30

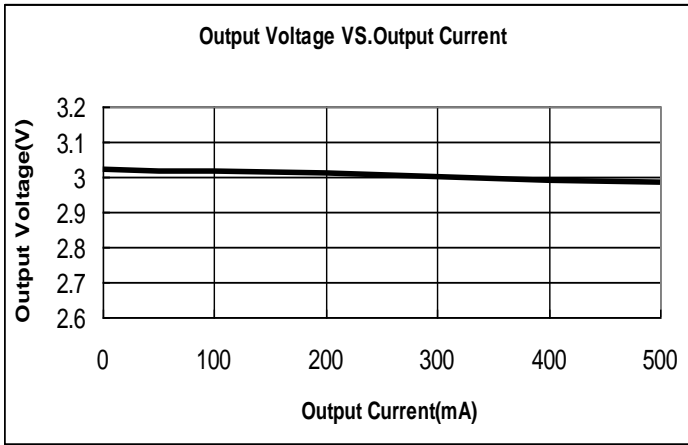

(2) Output Voltage VS. Input Voltage

($T_a = 25\text{ }^\circ\text{C}$, $I_{out}=10\text{mA}$) ME6210A30

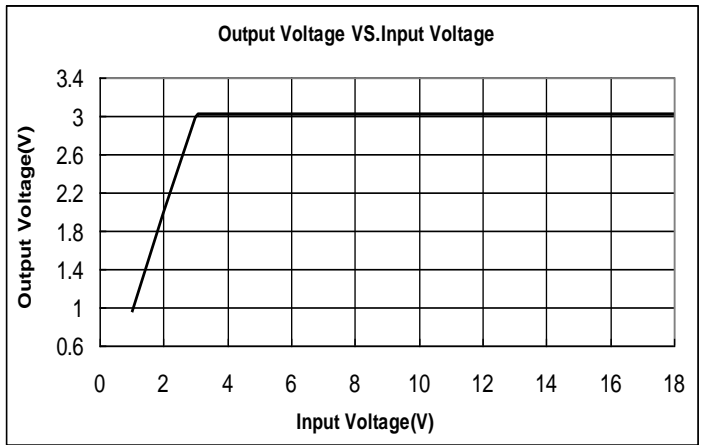

(3) Dropout Voltage VS. Output Current

($T_a = 25\text{ }^\circ\text{C}$) ME6210A30

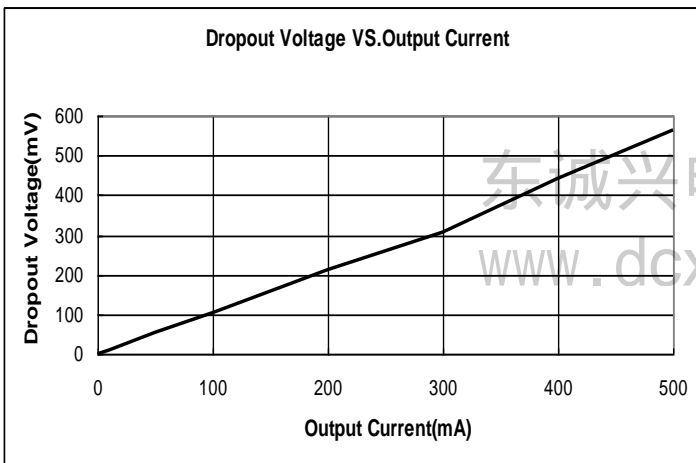

(4) Supply Current VS. Input Voltage

($T_a = 25\text{ }^\circ\text{C}$) ME6210A30

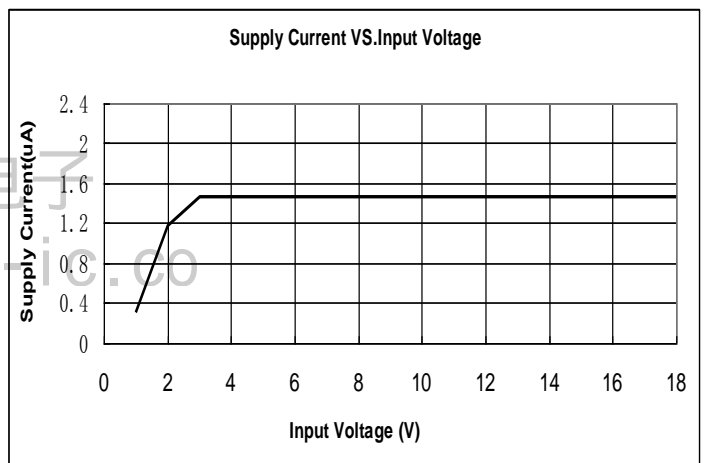

(5) Output Voltage VS. Temperature

($V_{IN}=4\text{V}$, $I_{out}=10\text{mA}$) ME6210A30

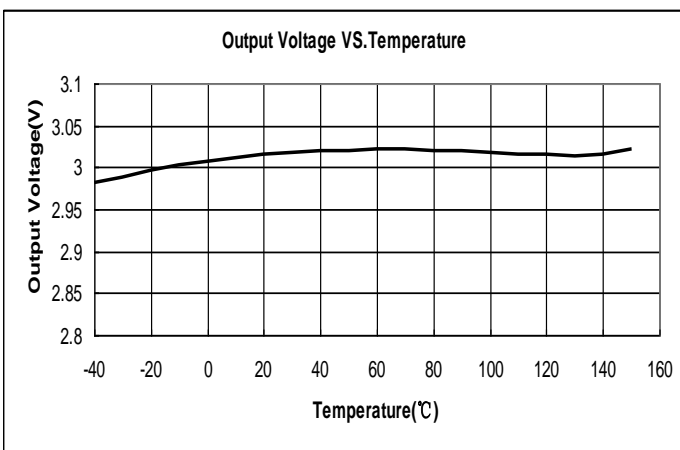

Packaging Information

- Package: SOT23-3

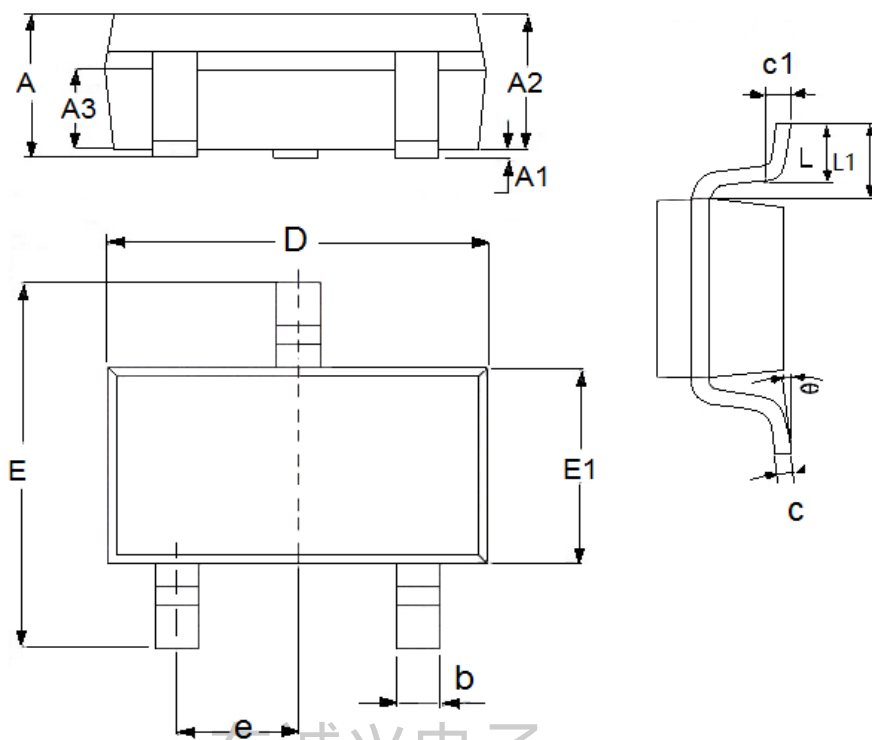

DIM	Millimeters		Inches	
	Min	Max	Min	Max
A	1.05	1.45	0.0413	0.0571
A1	0	0.15	0.0000	0.0059
A2	0.9	1.3	0.0354	0.0512
A3	0.6	0.7	0.0236	0.0276
b	0.25	0.5	0.0098	0.0197
c	0.1	0.25	0.0039	0.0098
D	2.8	3.1	0.1102	0.1220
E	2.6	3.1	0.1023	0.1220
E1	1.5	1.8	0.0591	0.0709
e	0.95(TYP)		0.0374(TYP)	
L	0.25	0.6	0.0098	0.0236
L1	0.59(TYP)		0.0232(TYP)	
θ	0	8°	0.0000	8°
c1	0.2(TYP)		0.0079(TYP)	

- Package: SOT89-3

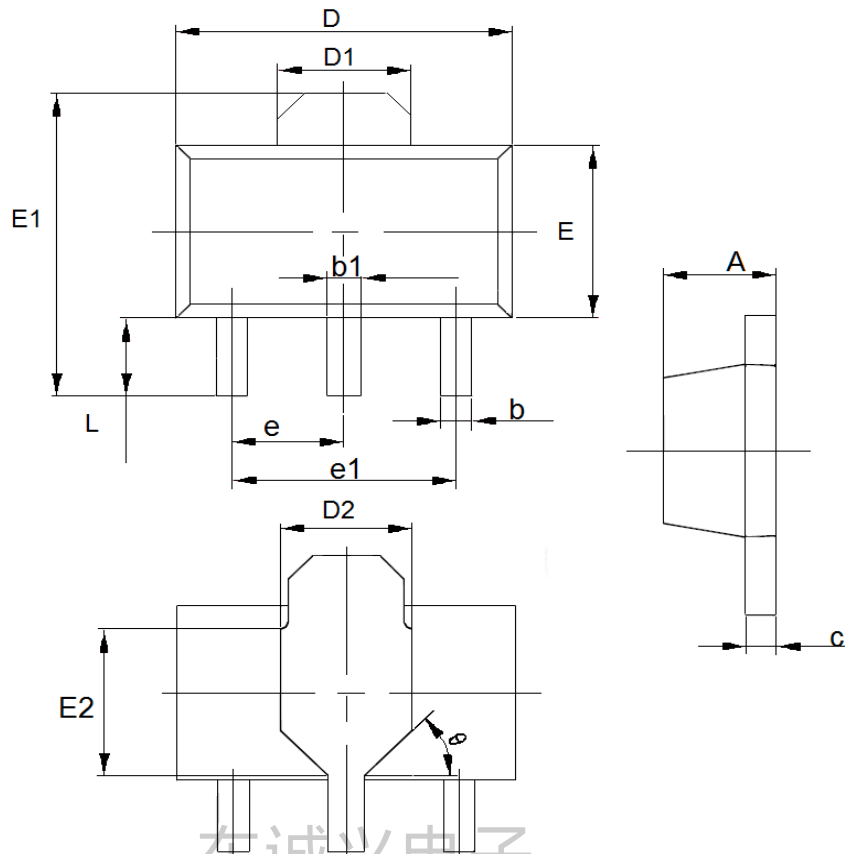

DIM	Millimeters		Inches	
	Min	Max	Min	Max
A	1.4	1.6	0.0551	0.0630
b	0.32	0.52	0.0126	0.0205
b1	0.4	0.58	0.0157	0.0228
c	0.35	0.45	0.0138	0.0177
D	4.4	4.6	0.1732	0.1811
D1	1.55(TYP)		0.061(TYP)	
D2	1.75(TYP)		0.0689(TYP)	
e1	3.0(TYP)		0.1181(TYP)	
E	2.3	2.6	0.0906	0.1023
E1	3.94	4.4	0.1551	0.1732
E2	1.9(TYP)		0.0748(TYP)	
e	1.5(TYP)		0.0591(TYP)	
L	0.8	1.2	0.0315	0.0472
θ	45°		45°	

- The contents of this document will be updated with the product's improvement without prior notice. Please consult our sales staff before using this document to ensure that you are using the latest version.
- The application circuit examples described in this document are only used to indicate the representative use of the product and do not guarantee the design of mass production.
- Please use this product within the limits stated in this document. We will not be responsible for any damage caused by improper use.
- The products described in this document are not allowed to be used in equipment or devices that affect the human body without the written permission of our company, including but not limited to: health equipment, medical equipment, disaster prevention equipment, fuel control equipment, automobile equipment, aviation equipment and vehicle equipment.
- Although our company has always been committed to improving product quality and reliability, semiconductor products have a certain probability of malfunction or wrong work. To prevent personal injury or property damage caused by such accidents, please pay full attention to safety design, for example: Alternate design, fire protection design, and prevention of wrong action design.
- When exporting this product or this document overseas, you should abide by applicable import and export control laws.
- Copying or reprinting part or all of this document in any form without the permission of our company is strictly prohibited.